

# The LM386 Audio Amplifier Project

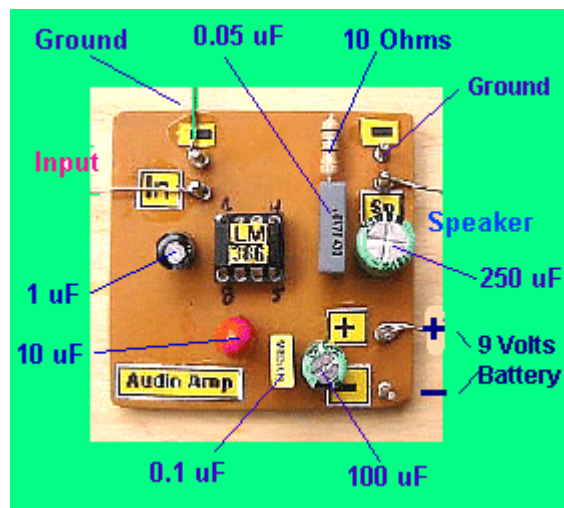

The LM386 IC has been designed to work with low voltages...between 4 to 15 volts. The current taken from the power source or the batteries when standing by, is also quite small, something around 3 mA's. If you add to these qualities the possibility of changing the amplification power, you realize that the LM386 chip is an attractive circuit to work with.

In the schematic to the right, you see that there is a capacitor between pins #1 and #8. This capacitor can be varied from 0.5uF to 10uF. With higher values employed, greater amplification can be obtained...though the risk of oscillation also increases.

To avoid oscillation of the circuit, it is a must to connect a 100uF electrolytic capacitor between pin #6 and ground. This capacitor is shunted in parallel with another one of 0.1uF. It can be either ceramic or mylar.

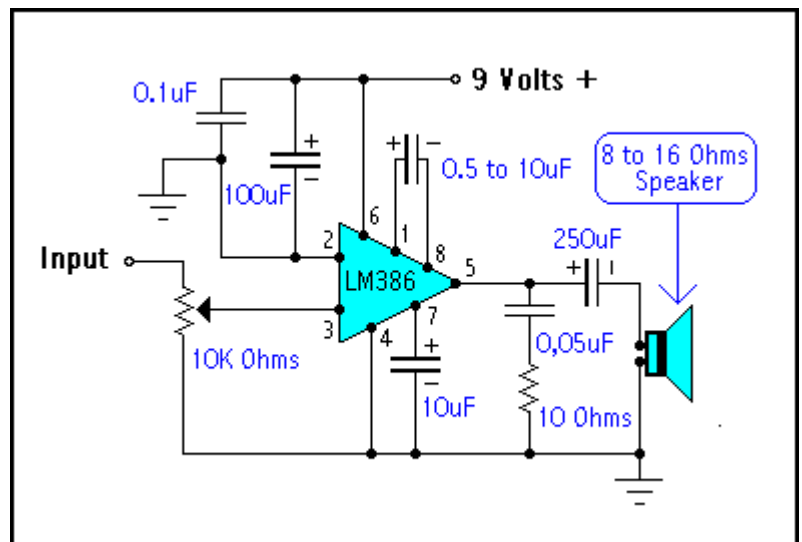

You can attach to the output of this circuit, speakers from 8 ohms to 16 ohms. I experimented with small speakers and even one of 7 inches in diameter showed excellent results!

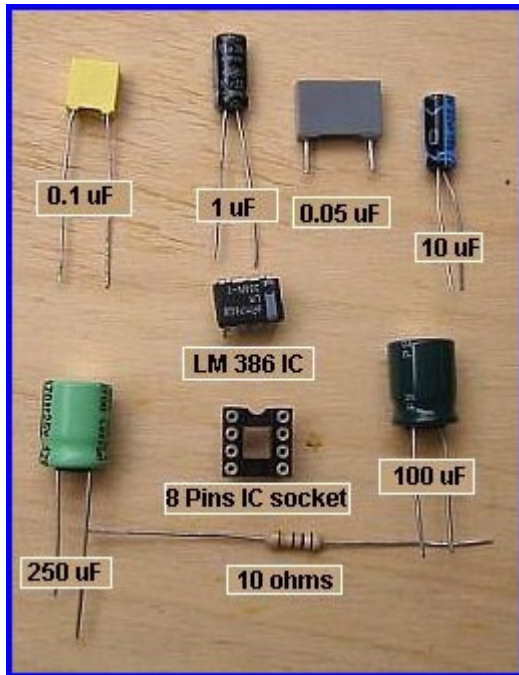

The picture to the left is all of the components used in the LM386 audio amplifier project.

The LM386 IC (Integrated Circuit) is manufactured in an 8 pin dual in-line package and it is good practice to mount it onto an 8 pin socket. This IC can deliver up to 0.5 (audio power) watts without any kind of heatsink. This is when a 16 ohm loudspeaker is attached to the output, together with a 9 volt power supply.

The LM386 IC has an ample field of experimentation...not only as an audio amplifier, but also as a Wienbridge oscillator and a square wave oscillator.

The picture to the right shows the 'copper tracks side' of the LM386 audio amplifier *printed circuit board (PCB)*.

